

We hope that the analysis offered in the paper will stimulate research on the effects of substituents on the stereochemistry of electrocyclic reactions. In conclusion, we would like to signal out the people who have expressed ideas related to the ideas contained in this paper. Most notably, Baldwin, *et al.*,¹⁶ have provided a classic experimental demonstration of the importance

(16) J. E. Baldwin and A. H. Andrist, *J. Amer. Chem. Soc.*, **93**, 3289 (1971).

of configuration interaction in lowering the barrier to isomerization of various olefins. These workers observed a linear relation between the activation energies of various thermal isomerizations and the ultraviolet transitions of the reactants.¹⁷

(17) Subsequent to submission of these papers, Breslow and co-workers reported some intriguing substituent effects on electrocyclic reactions which support the conclusions reached in this work: R. Breslow, J. Napierski, and A. H. Schmidt, *ibid.*, **94**, 5906 (1972).

Configuration Interaction and Organic Reactivity. III. Sigmatropic Reactions and Ionic Rearrangements

Nicolaos D. Epiotis*¹

Contribution from the Department of Chemistry, Princeton University, Princeton, New Jersey 08540. Received March 22, 1972

Abstract: The effect of configuration interaction on the stereoselectivity of sigmatropic reactions is examined by a simple molecular orbital approach. It is shown that configuration interaction can reverse the stereoselectivity of 1,3 sigmatropic shifts when the migration framework and the migrating group have widely different polarities. On the other hand, configuration interaction cannot reverse the stereoselectivity of 1,5 sigmatropic shifts. It is also shown that configuration interaction can reverse the stereoselectivity of certain 1,4 cationic and 1,2 anionic rearrangements but not that of 1,2 cationic and 1,4 anionic rearrangements. Experimental evidence relating to these predictions is discussed.

Configuration interaction is important in determining the stereoselectivity of cycloaddition and ring-closure reactions.² These ideas are now extended to sigmatropic reactions. Unfortunately, in these cases correlation diagrams cannot be formally constructed. Accordingly, we shall use a simple MO approach in order to gain insights about the effect of substituents on the stereoselectivity of sigmatropic shifts and, in particular, inquire whether configuration interaction can again be important in determining the stereoselectivity of such reactions.

1,3 Sigmatropic Shifts. The transition state of a 1,3 sigmatropic shift involves the interaction between the migrating group, which can be formally represented by the radical $R_3C\cdot$, and the migration framework, which can be formally represented by the allyl radical.

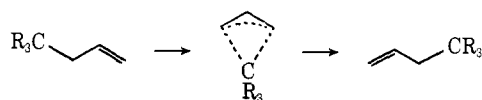

One can distinguish three types of substitution patterns and these are shown in Table I. We shall now examine in detail the stereoselectivity of the 1,3 carbon shift in each of the three cases.

Case I is a typical AX pericyclic process where the donor partner is the migrating group and the acceptor partner is the migration framework. In such a case, the migrating group is characterized by a low ionization potential and the migration framework is characterized by a high ionization potential. One can conveniently

(1) Address correspondence to the Department of Chemistry, University of Washington, Seattle, Wash. 98105.

(2) N. D. Epiotis, *J. Amer. Chem. Soc.*, **95**, 1191, 1200 (1973).

Table I. Types of Sigmatropic Migrations

Case	Designation	Substituents on migration framework ^a	Substituents on migrating group ^a
I	AX	Electron acceptor	Electron donor
IIa	AD	None	Simple alkyls
IIb	AD	Electron acceptor	Electron acceptor
IIc	AD	Electron donor	Electron donor
III	AX	Electron donor	Electron acceptor

^a Parent migration framework in the case of 1,3 shifts is the allyl radical and in the case of 1,5 shifts is the 1,3-pentadienyl radical. Parent migrating group is in both cases the methyl group.

derive the MO's of the transition state complex which involves inversion in the migrating center and the MO's of the transition state complex which involves retention in the migrating center from interaction diagrams.³ These are shown in Figure 1. The conclusions drawn from such interaction diagrams are straightforward and are stated below.

(1) Migration by inversion will be a concerted process since the lowest state configuration of the inversion transition state complex involves placing two electrons in an NBMO and two electrons in a BMO of the transition state complex. Thus, there is bonding along the union sites and the transition state is pericyclic in character.

(2) Migration by retention will involve an ion pair since the lowest state configuration of the retention transition state complex involves placing four electrons in two NBMO's of the transition state complex. The

(3) Interaction diagrams are constructed as indicated before and the MO's of the transition state complexes are calculated from perturbation theory.

two NBMO's of the retention transition state complex correspond to the BMO and the NBMO of the allyl migration framework and the ion pair involves a one electron transfer from the donor migrating group to the acceptor migration framework. Thus, there is no bonding along the union sites and the transition state is nonpericyclic in character.

We shall now see how configuration interaction can decisively modify the above conclusions which were reached on the basis of a one-electron treatment. In our further considerations we shall use the lowest diexcited configuration of the inversion and retention transition state complexes in order to test the effect of configuration interaction upon the stereoselectivity of the sigmatropic shifts. An examination of Figure 1 leads to the following apparent conclusions.

(1) In the case of the inversion transition state complex, configuration interaction is predicted not to be important in enhancing electrocyclic bonding. This arises because the lowest state and the diexcited configurations are of substantially different energies and, thus, mixing is expected to be very small. One should also notice that the diexcited configuration involves promoting two electrons from a BMO to a NBMO of the inversion transition state complex. In other words, inclusion of a diexcited configuration in the total wave function of the inversion transition state complex is expected to reduce pericyclic bonding. It is then expected that the transition state complex of a 1,3 shift proceeding with inversion is adequately described by a single lowest state configuration.

(2) In the case of the retention transition state complex, configuration interaction is predicted to be extremely important in generating electrocyclic bonding. This arises because the diexcited configuration involves promoting two electrons from a NBMO to a BMO of the retention transition state complex. In other words, inclusion of a diexcited configuration in the total wave function of the retention transition state complex is expected to generate strong pericyclic bonding. Furthermore, *strong mixing of the ground state and the diexcited configuration is fully expected since the energies of the two configurations are comparable.* This can be qualitatively seen in Figure 1 and has also been confirmed by a one electron orbital Hückel calculation of the energies of the two configurations. It is then expected that the transition state complex of a 1,3 shift proceeding with retention is adequately described by a linear combination of a ground state and a diexcited configuration.

We can now inquire about the relative electronic stabilization of the inversion and the retention transition states. We first note that the lowest state configuration of the inversion transition state complex is of lower energy than either the lowest state or the diexcited configuration of the retention transition state complex, but the difference in energy is in each case small. Furthermore, mixing of the ground state and diexcited configuration of the retention transition state complex will lead to further stabilization of the retention transition state complex and to strong pericyclic bonding. It is then expected that the electronic stabilization of the retention and inversion transition states will be similar and in cases might even be greater for the retention rather than the inversion transition state.

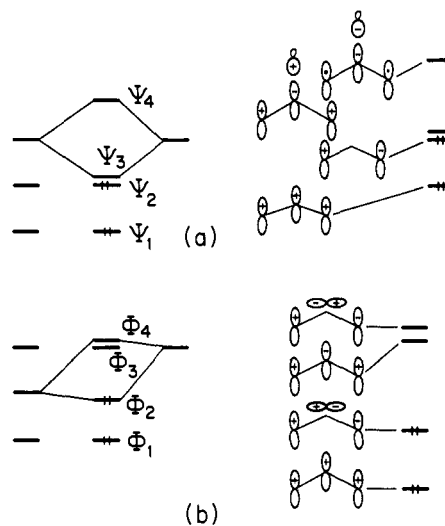
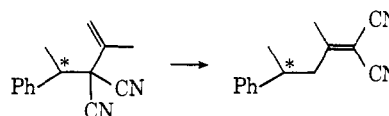

Figure 1. The MO's of the (a) retention and (b) inversion transition state complexes of a case I AX 1,3 sigmatropic reaction.

Up to this point, we have seen that electronic stabilization of the concerted 1,3 shift proceeding with retention can be similar in magnitude to the electronic stabilization of the concerted 1,3 shift proceeding with inversion. We have to additionally inquire about the relative importance of steric and rehybridization effects prior to making any predictions regarding the stereoselectivity of the reaction. It is rather apparent that migration with retention is much more favorable than migration with inversion when one considers such effects. Two apparent factors which will strongly favor the retention over the inversion pathway are stated below. (1) The inversion transition state involves severe nonbonded repulsions between the ligands of the migrating center and the migration framework, but the retention transition state is sterically unencumbered.⁴ (2) The inversion pathway requires rehybridization of the migrating center during the course of the reaction, but the retention pathway is free from such requirements.

In summary, steric and rehybridization effects favor the least motion pathway while electronic effects may favor either the least motion or the non least motion pathway to a similar extent. The situation is exactly analogous to that in AX 2 + 2 cycloadditions. It is expected that AX 1,3 sigmatropic shifts will proceed with retention rather than inversion and that configuration interaction is crucial in determining the stereoselectivity of such reactions.

Experimental evidence which strongly indicates our predictions to be valid has been obtained by Cookson, *et al.*⁵ Their results were compatible with a highly



stereoselective suprafacial migration involving retention of configuration in the migrating group in disagreement with the Woodward-Hoffmann rules and in agreement with our analysis. The migrating group and

(4) For experimental evidence relevant to this point, see J. A. Berson and R. G. Salomon, *J. Amer. Chem. Soc.*, **93**, 4620 (1971).

(5) R. C. Cookson and J. E. Kemp, *Chem. Commun.*, 385 (1971).

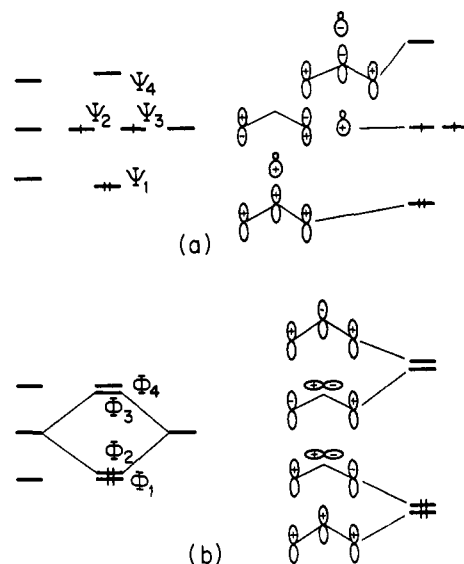
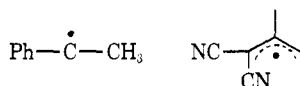

Figure 2. The MO's of the (a) retention and (b) inversion transition state complexes of a case II AD 1,3 sigmatropic reaction.

migration framework of this reaction are shown below and it is apparent that they belong to substitution pattern I.



Case II is a typical AD pericyclic process where the donor partner can be either the migrating group or the migration framework. In such a case, both migrating group and migration framework have comparable ionization potentials. The MO's of the inversion and retention transition states are derived in the same manner as in the previous case and are shown in Figure 2. The conclusions drawn from an examination of Figure 2 are straightforward and are stated as follows.

(1) Migration by inversion will be a concerted process since the lowest state configuration of the inversion transition state complex involves placing two electrons in a NBMO and two electrons in a BMO of the transition state complex. Thus, there is bonding along the union sites and the transition state is pericyclic in character.

(2) Migration by retention will also be a concerted process since the lowest state configuration of the retention transition state involves placing two electrons in a BMO and two electrons in a pair of nearly degenerate NBMO's. Thus, there is bonding along the union sites and the transition state is pericyclic in nature.

We shall now examine whether configuration interaction can modify the above conclusions which were reached on the basis of a one-electron treatment. An examination of Figure 2 leads to the following apparent conclusions. (1) In the case of the inversion transition state complex, configuration interaction is predicted not to be important in enhancing pericyclic bonding. This arises because the lowest state and the diexcited configurations are of substantially different energies and, hence, mixing is expected to be very small. One should also notice that the diexcited configuration involves promoting two electrons from a BMO to an ABMO of the inversion transition state complex. (2)

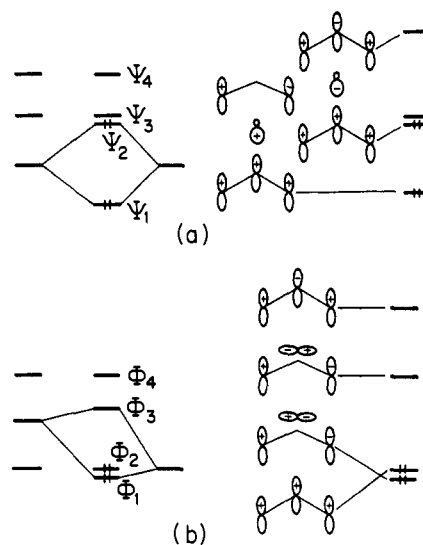

Figure 3. The MO's of the (a) retention and (b) inversion transition state complexes of a case III AX 1,3 sigmatropic reaction.

In the case of the retention transition state complex, configuration interaction is predicted not to be important in enhancing pericyclic bonding. The reasons are similar to the ones of the previous case involving the inversion transition state.

Thus, it can be seen that in the case of migration by inversion and in the case of migration by retention configuration interaction will not enhance pericyclic bonding. Accordingly, a lowest state configuration adequately describes both the inversion and the retention transition states. It can be readily seen by reference to Figure 2 that the lowest state configuration of the inversion transition state complex is of much lower energy than the lowest state configuration of the retention transition state complex.⁶ In this case electronic effects strongly favor the non least motion pathway. On the other hand, steric and rehybridization effects favor the least motion pathway. We conclude that in 1,3 sigmatropic shifts of this type, electronic effects can dominate steric and rehybridization effects and the reaction follows the non least motion pathway. The situation is exactly analogous to the situation in AD 2 + 2 cycloadditions. It is expected that AD 1,3 sigmatropic shifts will proceed with inversion and that configuration interaction is not crucial in determining the stereoselectivity of such reactions.

Experimental evidence supporting these conclusions is already available. Berson and Nelson⁷ have provided an example of 1,3 sigmatropic migration involving a migration framework and a migration group of similar polarities. The reaction was found to proceed suprafacially with inversion of configuration in the migrating group, in agreement with both the Woodward-Hoffmann and our conclusions.

Case III is a typical AX pericyclic process where the migration framework is the donor partner and the

(6) A better description of the lowest state of the retention transition state involves not a single lowest state configuration $\psi_1^2\psi_2^1\psi_3^1$ but a linear combination of the lowest state configurations $\psi_1^2\psi_2^1\psi_3^1$, $\psi_1^2\psi_2^2$, and $\psi_1^2\psi_3^2$. However, the electronic energy of such a state would probably be higher than the electronic energy of the lowest state configuration of the inversion transition state.

(7) J. A. Berson and G. L. Nelson, *J. Amer. Chem. Soc.*, **89**, 5303 (1967); J. A. Berson, *Accounts Chem. Res.*, **1**, 152 (1968).

migrating group is the acceptor partner. In such a case, the migration group is characterized by a high ionization potential and the migration framework is characterized by a low ionization potential. The MO's of the inversion and retention transition states are derived in the same manner as in the previous cases and are shown in Figure 3. The conclusions drawn from an examination of Figure 3 by following the same reasoning as before are identical with the conclusions drawn in the case of the AX electrocyclic process discussed before (case I AX electrocyclic process). One concludes that in case III electronic effects favor the least motion and the non least motion pathway to a similar extent, while steric and rehybridization effects favor the least motion pathway. The situation is exactly analogous to the situation in AX 2 + 2 cycloadditions. It is expected that AX 1,3 sigmatropic shifts of the type discussed in this section will proceed with retention rather than inversion and that configuration interaction is crucial in determining the stereoselectivity of such reactions.

Experimental evidence relevant to these predictions has been recently reported by Klärner.⁸ He studied the reaction shown below and found that 1,3 migration was occurring with a high degree of retention in the migrating group.

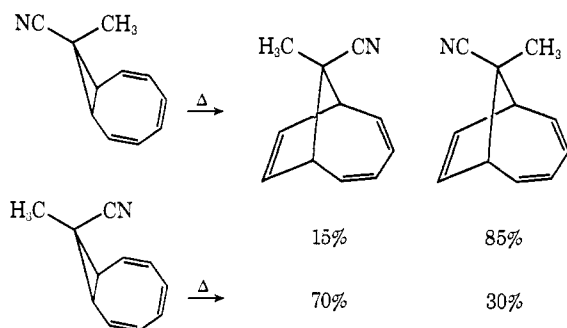

The migration framework and migrating group of this AX-like sigmatropic shift are shown below, and it is apparent that they approximate the substitution pattern III. Replacement of the CH_3 group by a CF_3 group is expected to enhance retention in the migrating group.

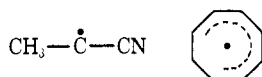

1,5 Sigmatropic Shifts. The transition state of a 1,5 sigmatropic shift involves the interaction between the migrating group, which can be formally represented by the radical $\text{R}_3\text{C}\cdot$, and the migration framework, which can be formally represented by the pentadienyl radical.

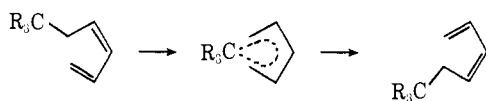

One can distinguish three types of substitution patterns and these are the same as in the case of 1,3 sigmatropic shifts (Table I). We shall examine, in the same manner as before, the stereoselectivity of the 1,5 carbon shift in each of the three cases.

(8) F. G. Klärner, *Tetrahedron Lett.*, 3611 (1971).

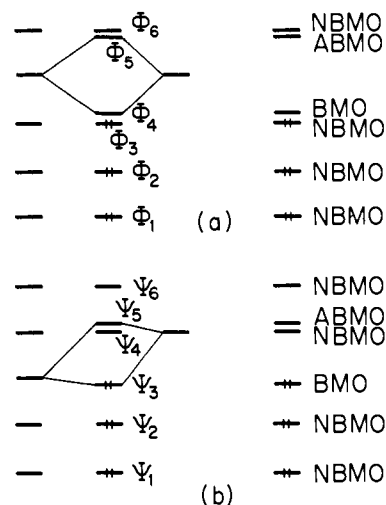

Figure 4. The MO's of the (a) inversion and (b) retention transition state complexes of a case I AX 1,5 sigmatropic reaction.

Case I is a typical AX pericyclic process where the donor partner is the migrating group and the acceptor partner is the migration framework. The MO's of the inversion and retention transition state complexes are shown in Figure 4. By using the same reasoning as in case I of the 1,3 sigmatropic shift, we conclude the following.

(1) The lowest state configuration of the retention transition state complex involves pericyclic bonding. Configuration interaction will not be important since the lowest state and diexcited configurations have widely different energies. It should also be noted that the diexcited configuration involves promoting two electrons from a BMO to a NBMO! Thus, the retention transition state is adequately described by a single ground state configuration.

(2) The lowest state configuration of the inversion transition state complex is an ion pair and a diexcited configuration which involves promoting two electrons from a NBMO to a BMO will strongly mix with the ground state configuration and generate pericyclic bonding. This will occur because the two configurations are of comparable energy. Hence, the inversion transition state is adequately described by a linear combination of the lowest state and diexcited configurations.

(3) The inversion and retention pathways are electronically stabilized to a comparable extent, but steric and rehybridization effects favor the retention pathway. It is concluded that the migration will occur by retention in the migrating center.

Case II is a typical AD pericyclic process. The MO's of the inversion and retention transition state complexes are shown in Figure 5. By using the same reasoning as in case II of the 1,3 sigmatropic shift, we conclude the following.

(1) The lowest state configuration of both the retention and inversion transition state complexes involve pericyclic bonding, and configuration interaction is not expected to be important since the lowest state and diexcited configurations are energetically dissimilar in both cases. One should also note that in both cases, the diexcited configuration involves promoting two electrons from a more bonding to a less bonding orbital.

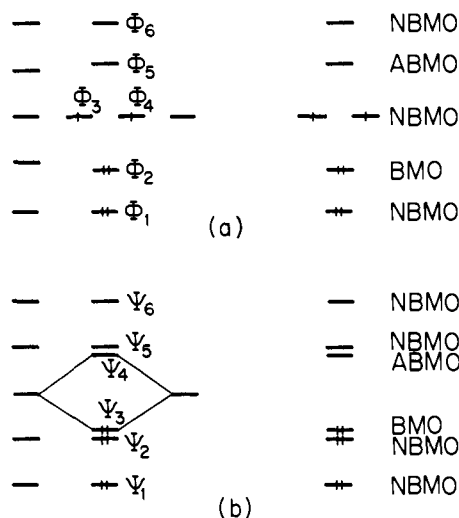

Figure 5. The MO's of the (a) inversion and (b) retention transition state complexes of a case II AD 1,5 sigmatropic reaction.

(2) The lowest state configuration of the retention transition state complex is of much lower energy than the ground state configuration of the inversion transition state complex.⁹ Accordingly, the retention pathway is stabilized by electronic, steric, and rehybridization effects to a much greater extent than the inversion pathway. It is concluded that the migration will occur by retention in the migrating center.

Case III is a typical AX pericyclic process where the donor partner is the migration framework and the acceptor partner is the migrating group. The MO's of the inversion and retention transition state complexes are shown in Figure 6. By using the same reasoning as in case III of the 1,5 sigmatropic shift, we conclude that migration will occur by retention in the migrating center. On the basis of these considerations, it is concluded that 1,5 sigmatropic shifts will occur with retention in the migrating group throughout the entire reactivity spectrum. Experimental evidence which shows that these conclusions are valid has been cited by Woodward and Hoffmann.¹⁰ These cases are typical AM 1,5 sigmatropic reactions. Typical AX 1,5 sigmatropic reactions have not yet been studied.

In this section we saw that configuration interaction is of paramount importance in determining the stereoselectivity of sigmatropic reactions, and 1,3 and 1,5 sigmatropic shifts form a reactivity spectrum ranging from migrations involving a migration framework and a migrating group of similar polarities and migrations involving a migration framework and a migrating group of widely different polarities. It is predicted that 1,3 sigmatropic migrations which fall in the middle of this reactivity spectrum will be nonstereoselective, not necessarily because of the intermediacy of a diradical or a dipolar species, but possibly because of the competition between two of concerted processes of different stereoselectivity. A similar interpretation of the stereo-

(9) A better description of the lowest state of the inversion transition state involves not a single lowest state configuration $\phi_1^2\phi_2^2\phi_3^1\phi_4^1$ but a linear combination of the lowest state configurations $\phi_1^2\phi_2^2\phi_3^1\phi_4^1$, $\phi_1^2\phi_2^2\phi_3^2$, and $\phi_1^2\phi_2^2\phi_4^2$. However, the electronic energy of such a state would probably be higher than the electronic energy of the lowest state configuration of the retention transition state.

(10) R. B. Woodward and R. Hoffmann, *Angew. Chem., Int. Ed. Engl.*, **8**, 781 (1969).

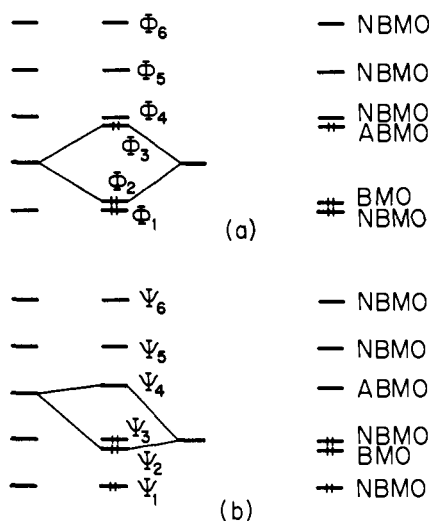

Figure 6. The MO's of the (a) inversion and (b) retention transition state complexes of a case III AX 1,5 sigmatropic reaction.

selectivity of thermal and photochemical intermolecular cycloadditions has already been presented. An approximate index for locating a 1,3 sigmatropic migration on the reactivity spectrum is provided by the difference of ionization potentials of the migration framework and of the migrating group. At the AD extreme of the spectrum, the absolute magnitude of this index will be negligibly small while at the AX extreme of the spectrum the absolute magnitude of this index will be large. In contrast to 1,3 sigmatropic reactions, the stereoselectivity of 1,5 sigmatropic reactions is expected to be the same throughout the entire reactivity spectrum. The implications of this analysis will be discussed later.

Ionic Rearrangements

1,2 Cationic Shift. A typical migration within a cation is shown below. The transition state of the



migration involves the interaction between the migrating group, which can be formally represented by the carbonium ion R_3C^+ , and the migration framework, which can be formally represented by ethylene. One can distinguish two substitution patterns and these are listed in Table II. Other substitution patterns will be intermediate between these two substitution patterns.

We first examine case I. The MO's of the inversion and retention transition state complexes are shown in Figure 7. It is clear that the lowest state configuration of the retention transition state complex is of much lower energy than the lowest state configuration of the inversion transition state complex, and that in both cases there is bonding along the union sites. We can now inquire about the effect of configuration interaction on the relative stabilization of the two transition state complexes. As in all previous cases, we shall only consider the lowest diexcited configuration of the retention and inversion transition state complexes. Consideration of the relative energies of the lowest state and diexcited configurations leads to the conclusion that configuration interaction will be unimportant in

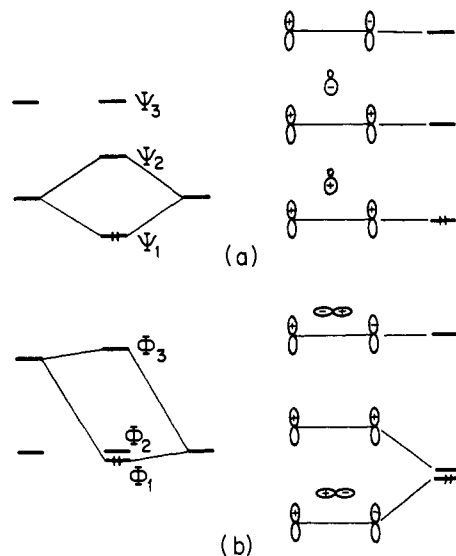

Figure 7. The MO's of the retention (a) and inversion (b) transition state complexes of a case I AD cationic 1,2 migration.

Table II. Types of Ionic Migrations

Reaction	Designation	Substituents on migration framework	Substituents on migrating group
1,2 cationic ^a shift			
Ia	AD	None	None
Ib	AD	Electron donor	Electron donor
Ic	AD	Electron acceptor	Electron acceptor
II	AX	Electron acceptor	Electron donor
1,4 cationic ^b shift			
I	AX	Electron donor	Electron acceptor
IIa	AD	None	Simple alkyls
IIb	AD	Electron donor	Electron donor
IIc	AD	Electron acceptor	Electron acceptor
III	AX	Electron acceptor	Electron donor
1,2 anionic ^c shift			
I	AX	Electron donor	Electron acceptor
IIa	AD	None	None
IIb	AD	Electron donor	Electron donor
IIc	AD	Electron acceptor	Electron acceptor
1,4 anionic ^d shift			
I	AX	Electron donor	Electron acceptor
IIa	AD	None	None
IIb	AD	Electron donor	Electron donor
IIc	AD	Electron acceptor	Electron acceptor

^a Parent migration framework is ethylene and parent migrating group is the methyl "cation." ^b Parent migration framework is butadiene and parent migrating group is the methyl "cation." ^c Parent migration framework is ethylene and parent migrating group is the methyl "anion." ^d Parent migration framework is butadiene and parent migrating group is the methyl "anion."

the retention transition state but important in the inversion transition state. One can then expect that the inversion transition state might be additionally stabilized due to configuration interaction but would not probably attain comparable electronic stabilization as the retention transition state. It is pertinent to note that strong configurational mixing will tend to diminish pericyclic bonding since the diexcited configuration involves promoting two electrons from BMO to a NBMO. Furthermore, steric and rehybridization effects are also important in addition to electronic effects. It is rather apparent that the inversion transition state involves nonbonded repulsions between the ligands of the migrating center and the migration frame-

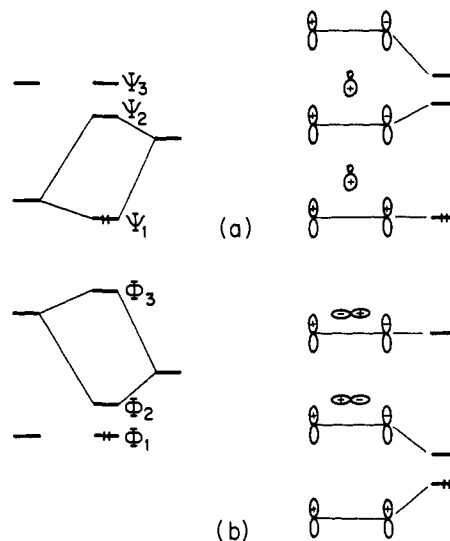

Figure 8. The MO's of the retention (a) and inversion (b) transition state complexes of a case II AX cationic 1,2 migration.

work, while the retention transition state is sterically unencumbered. Furthermore, the inversion transition state requires rehybridization of the migrating center along the reaction path, while the retention transition state does not require so.

It is concluded that in case I electronic, steric, and rehybridization effects all favor a 1,2 cationic migration by retention.

We shall now examine case II. The MO's of the inversion and retention transition state complexes are shown in Figure 8. It is clear again that the lowest state configuration of the retention transition state complex is of much lower energy than the lowest state configuration of the inversion transition state complex, but the energy difference is small. Furthermore, the retention transition state involves bonding along the union sites, while the inversion transition state does not involve bonding along the union sites and constitutes an ionic complex. We can now inquire about the effect of configuration interaction on the relative stabilization of the two transition state complexes. Consideration of the relative energies of the lowest state and diexcited configurations leads to the conclusion that configuration interaction will be unimportant for the retention transition state, but important for the inversion transition state. In the latter case, a diexcited configuration involves promoting two electrons from a NBMO to a BMO of the transition state complex. Hence, mixing of the two configurations is expected to lead to pericyclic bonding. The lowest state configuration of the retention transition state complex is of lower energy than the lowest state configuration of the inversion transition state complex. However, it should be noted that the energy difference is small and mixing of the lowest state and the diexcited configurations of the inversion transition state complex further reduces the energy of the inversion transition state. Thus, the electronic stabilization of the retention and inversion transition states is predicted to be comparable. By recognizing that steric and rehybridization effects favor the retention transition state, we are led to the conclusion that in case II, like in case I, a 1,2 cationic migration will proceed with retention.

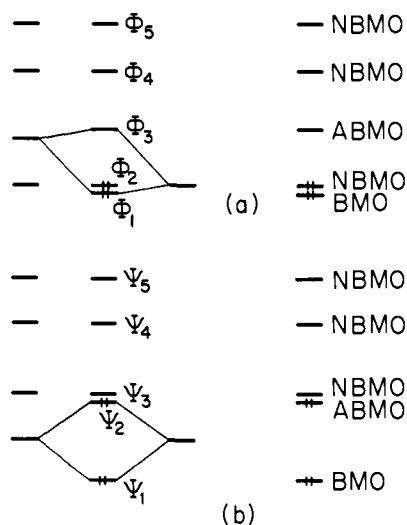
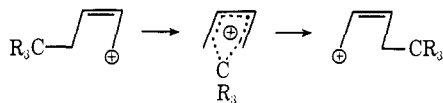

Figure 9. The MO's of the inversion (a) and retention (b) transition state complexes of a case I AX cationic 1,4 migration.

According to the above discussion, all 1,2 cationic migrations are expected to proceed with retention. Experimental evidence indicating that these expectations materialize has been summarized.¹¹

1,4 Cationic Shift. A typical 1,4 migration within a cation is shown below. The transition state of the



migration involves the interaction between the migrating group, which can be formally represented by the carbonium ion R_3C^+ , and the migration framework, which can be formally represented by butadiene. One can distinguish three substitution patterns and these are listed in Table I. Other substitution patterns will be intermediate between any two of the three substitution patterns. We first examine case I. The MO's of the inversion and retention transition state complexes are shown in Figure 9. It is clear that the lowest state configuration of the inversion transition state complex is of lower energy than the lowest state configuration of the retention transition state complex, but the energy difference is small. Furthermore, the inversion transition state involves bonding along the union sites, while the retention transition state does not involve bonding along the union sites and constitutes an ionic complex. We can now inquire about the effect of configuration interaction on the relative stabilization of the two transition state complexes. Consideration of the relative energies of the lowest state and diexcited configurations leads to the conclusion that configuration interaction will be unimportant in the inversion transition state but important in the retention transition state. In the latter case, a diexcited configuration involves promoting two electrons from an ABMO to a NBMO of the transition state complex. Hence, mixing of the lowest state and diexcited configurations is expected to lead to pericyclic bonding. The lowest state configuration of the inversion transition state is as we saw of lower energy than the lowest state configuration

(11) See reviews by Y. Pocker and J. A. Berson in "Molecular Rearrangements," Interscience, New York, N. Y., 1963.

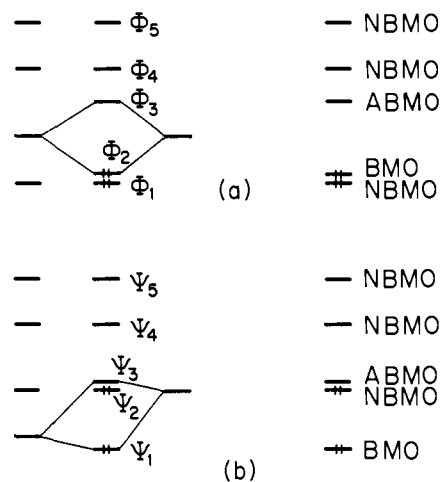

Figure 10. The MO's of the inversion (a) and retention (b) transition state complexes of a case II AD cationic 1,4 migration.

of the retention transition state. However, the energy difference is small and mixing of the lowest state and the diexcited configurations of the retention transition state complex further reduces the energy of the retention transition state. Thus, the electronic stabilization of the retention and inversion transition states is predicted to be comparable. By recognizing that steric and rehybridization effects favor the retention transition state, we are led to the conclusion that in this case a 1,4 cationic migration will proceed with retention.

We shall now examine case II. The MO's of the inversion and retention transition state complexes are shown in Figure 10. It is clear that the lowest state configuration of the inversion transition state complex is of much lower energy than the lowest state configuration of the retention transition state complex and that in both cases there is bonding along the union sites. We can now inquire about the effect of configuration interaction on the relative stabilization of the two transition state complexes. Consideration of the relative energies of the lowest state and diexcited configurations leads to the conclusion that configuration interaction will be unimportant in the inversion transition state but important in the retention transition state. One can then expect that in this case the retention transition state might be additionally stabilized due to configuration interaction, but would not probably attain comparable electronic stabilization as the inversion transition state. Again, it is pertinent to note that configuration mixing will tend to diminish pericyclic bonding. It is concluded that in case II one can reasonably expect electronic effects to dominate steric and rehybridization effects and the 1,4 migration is expected to occur with inversion. However, in this particular case, an actual computation test might be desirable.

Finally, we consider case III. The MO's of the inversion and retention transition state complexes are shown in Figure 11. By using the same reasoning as in case I, we conclude that migration will occur with retention in the migration center.

Experimental evidence relevant to these predictions is only available for the AD type migrations and has been discussed by Woodward and Hoffmann. It will be interesting to investigate AX cases which will provide a good test of our theory. It should be noted that in

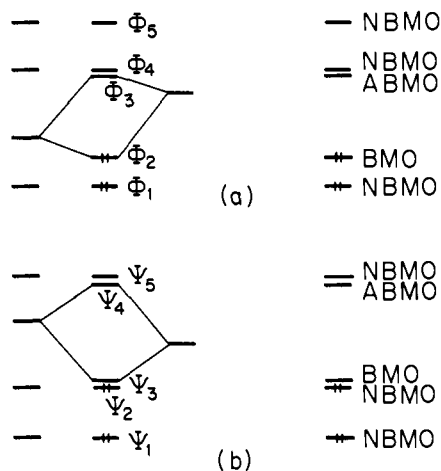

Figure 11. The MO's of the inversion (a) and retention (b) transition state complexes of a case III AX cationic 1,4 migration.

1,4 cationic migrations nonstereoselectivity in the middle of the reactivity spectrum is expected as a result of competing concerted processes involving retention and inversion in the migrating center.

1,2 Anionic Shift. A typical migration within an anion is shown below. The transition state of the



migration involves the interaction between the migrating group, which can be formally represented by the carbanion R_3C^- , and the migration framework, which can be formally represented by ethylene. One can distinguish two substitution patterns and these are shown in Table II. Other substitution patterns will be intermediate between these two substitution patterns.

In the case of 1,2 anionic rearrangements we employ the same reasoning as in the case of 1,2 cationic rearrangements. The MO's of the inversion and retention transition state complexes for case I are shown in Figure 12 and the MO's of the inversion and retention transition state complexes for case II are shown in Figure 13. By going through the series of familiar arguments, we conclude that a case I 1,2 anionic migration will proceed with retention while a case II 1,2 anionic migration will proceed with inversion.

Experimental evidence relevant to these predictions is inconclusive. In any event, the Woodward-Hoffmann result is not obtained in cases which have been investigated. Stepwise processes or concerted processes involving retention on account of the reasons presented here are possible explanations of the observed results. Certainly, more research is needed in this area of organic ionic rearrangements. In the case of 1,2 anionic shifts, it should be noted that nonstereoselectivity in the middle of the reactivity spectrum is expected as a result of competing concerted processes involving retention and inversion in the migrating center.

1,4 Anionic Shift. A typical 1,4 migration within an anion is shown below. The transition state of the migration involves the interaction between the migrating group, which can be formally represented by the carbanion R_3C^- , and the migration framework,

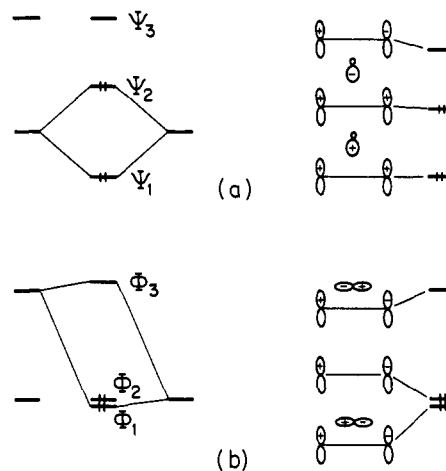

Figure 12. The MO's of the retention (a) and inversion (b) transition state complexes of a case I AD anionic 1,2 migration.

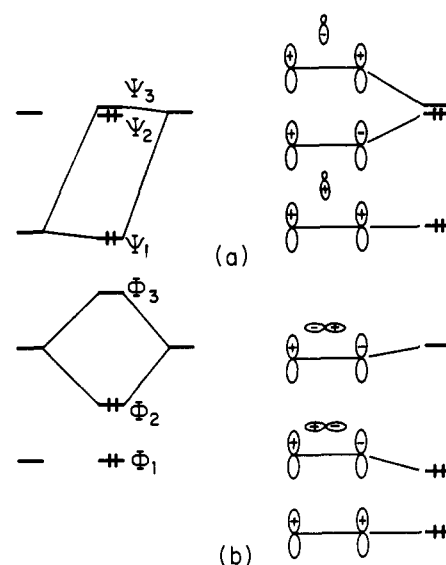
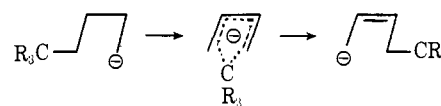

Figure 13. The MO's of the retention (a) and inversion (b) transition state complexes of a case II AX anionic 1,2 migration.



which can be formally represented by butadiene. One can distinguish two substitution patterns and these are shown in Table I. Any other substitution pattern will be intermediate between these two substitution patterns.

In the case of 1,4 anionic rearrangements, we employ the same reasoning as in the case of 1,4 cationic rearrangements. The MO's of the inversion and retention transition state complexes for case I are shown in Figure 14 and the MO's of the inversion and retention transition state complexes for case II are shown in Figure 15. By going through the series of familiar arguments, we conclude that both a case I and a case II 1,4 anionic migration will proceed with retention.

Experimental evidence to test these predictions is not available. It is hoped that this article will stimulate some research activity in this area.

In conclusion, we have seen that in ionic migrations

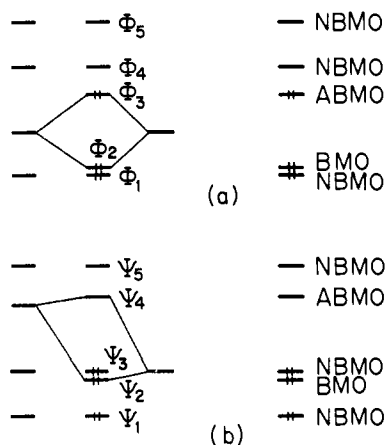

Figure 14. The MO's of the inversion (a) and retention (b) transition state complexes of a case I AD anionic 1,4 migration.

the forbiddenness of a least motion process is removed whenever there can be strong configuration interaction. This result is similar to results obtained in the cases of intermolecular cycloadditions and sigmatropic reactions. The full implications of these results will be discussed in greater detail in the next article.

Finally, it is rather apparent that approximate indices for locating a particular ionic migration on the reactivity spectrum are rather readily available as in the cases of intermolecular cycloadditions and sigmatropic reactions. In the case of cationic rearrangements, an AD migration will occur whenever the ionization potential of the migration framework and the ionization potential of the formal radical, which corresponds to the migrating formal cation, are similar in magnitude. On

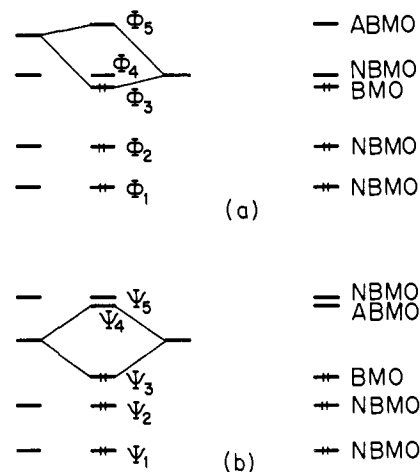

Figure 15. The MO's of the inversion (a) and retention (b) transition state complexes of a case II AX anionic 1,4 migration.

the other hand, an AX migration will obtain whenever the ionization potential of the migration framework and the ionization potential of the formal radical corresponding to the migrating formal cation are extremely different in magnitude. In the case of anionic rearrangements, an AD migration will obtain whenever the ionization potential of the migration framework and the electron affinity of the migrating formal anion are extremely different and an AX migration will obtain whenever the ionization potential of the migration framework and the electron affinity of the migrating group are similar.¹²

(12) In this work we only examined the stereochemistry of suprafacial migrations. The same approach can be used to examine the stereochemistry of the less probable antarafacial migrations.

Configuration Interaction and Organic Reactivity.

IV. Concepts and Generalizations

Nicolaos D. Epitotis¹

Contribution from the Department of Chemistry, Princeton University, Princeton, New Jersey 08540. Received March 22, 1972

Abstract: On the basis of our previous findings it is concluded that configuration interaction can reverse the stereoselectivity of $4N$ electron pericyclic processes but not that of $4N + 2$ electron pericyclic processes. The importance of configuration interaction in reducing or removing the forbiddenness of certain pericyclic processes is further illustrated by consideration of front-side nucleophilic displacement on saturated carbon. Some important implications of these findings are also discussed.

In the previous articles, we examined the effect of configuration interaction on the stereoselectivity of pericyclic reactions. The results of this study are collected in Table I. An examination of Table I leads to the following generalizations.

(a) All pericyclic reactions form a reactivity spectrum which varies continuously from AA to AZ pericyclic processes.

(1) Address correspondence to the Department of Chemistry, University of Washington, Seattle, Wash. 98105.

(b) Configuration interaction is important in most pericyclic AX processes and can be neglected in most AD pericyclic processes.

(c) Configuration interaction can lead to reversal of stereoselectivity in $4N$ electron pericyclic processes by rendering the stereoselectivity of the AX reactions opposite to the stereoselectivity of the AD reactions. In such $4N$ electron pericyclic processes, the intermediate region of the reactivity spectrum will be constituted of reactions which are nonstereoselective. The